

- DATUMS:
 -A- MOUNTING FACE OF FLYWHEEL
 -B- ENGINE CRANKSHAFT HORIZONTAL CENTERLINE
 -C- ENGINE CRANKSHAFT VERTICAL CENTERLINE
 -D- PUMP INPUT SHAFT OR RIGHT ANGLE GEAR INPUT SHAFT HORIZONTAL CENTERLINE
 -E- PUMP INPUT SHAFT OR RIGHT ANGLE GEAR INPUT SHAFT VERTICAL FACE

CAUTION:
 ALL PLUMBING MUST BE SUPPORTED AND/OR ISOLATED SO THAT NO WEIGHT OR STRESS IS APPLIED TO ANY ENGINE COMPONENT.

INSTALLATION NOTES:

- CAUTION: SPREADER BARS REQUIRED TO MOVE PACKAGE DUE TO IMPROPER HANDLING IS NOT WARRANTABLE
- FUEL SUPPLY PIPING FROM TANK TO ENGINE SHOULD BE 1/2" MINIMUM PIPE DIAMETER
- FUEL RETURN PIPING FROM TANK TO ENGINE SHOULD BE 3/8" MINIMUM PIPE DIAMETER
- PIPING & CABLING CONNECTIONS BETWEEN THE DIESEL ENGINE CONTROLLER & FUEL TANK TO BE DONE BY CUSTOMER. FUEL TANK & CONTROLLER TO BE INSTALLED ACCORDING TO NFPA-20 AND ENGINE MANUFACTURER RECOMMENDATIONS.
- SILENCER, MOUNTING BRACKETS, MOUNTING BANDS, FLAPPER, RAIN CAP, AND HARDWARE TO BE SHIPPED SEPARATELY ON A SKID AND INSTALLED ON SITE.
- ENGINE, FRAME, AND ENCLOSURE TO BE THE COLOR: RAL 3001 SIGNAL RED.
- ENCLOSURE FINISH TO BE TEXTURED POWDER COAT.
- ENCLOSURE MATERIAL: 0.10" THICK 5052 H32 ALUMINIUM
- FOR ESTIMATED TOTAL WEIGHT AND SHIPPING DIMENSIONS SEE DRAWING C137470.
- OFFSET "G" CAN BE ABOVE OR BELOW DATUM B. THIS OFFSET IS REQUIRED AND IS THE RESPONSIBILITY OF THE CUSTOMER TO SET THE PROPER HEIGHT FOR THE PUMP. SEE DRAWING D769 FOR OFFSET FOR PUMP SHAFT WITH OR WITHOUT A TORSIONAL COUPLING

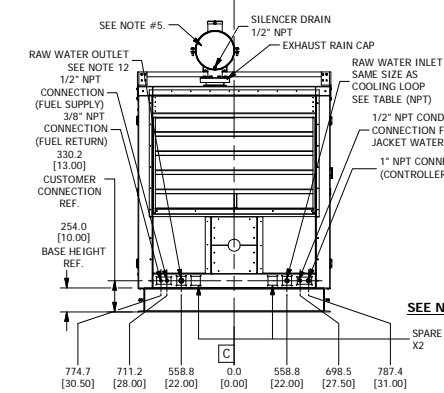
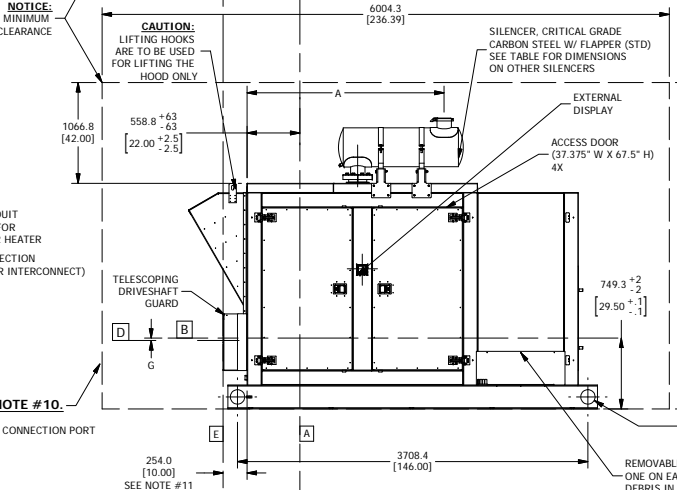
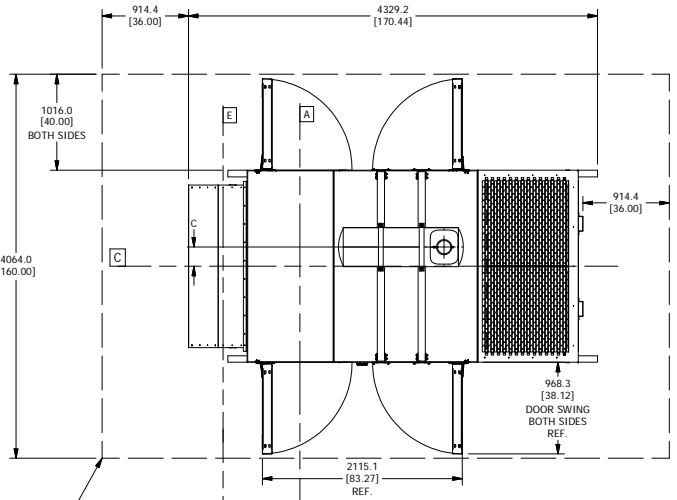

- NOTES CONTINUED**
- LOCATION OF THE PUMP INPUT SHAFT OR RIGHT ANGLE GEAR INPUT SHAFT IS HELD BY CONTROLLING THE COMBINATION OF DRIVE PLATE OR TORSIONAL COUPLING AND THE DRIVESHAFT.
 - PER NFPA 20 11.2.8.7.1 AN OUTLET SHALL BE PROVIDED FOR THE WASTEWATER LINE FROM THE HEAT EXCHANGER, AND THE DISCHARGE SHALL NOT BE LESS THAN ONE SIZE LARGER THAN THE INLET LINE. ALSO PER NFPA 20 11.2.8.7.4 WHEN THE WASTE OUTLET PIPING IS LONGER THAN 15' (4.6 m) OR ITS OUTLET DISCHARGES ARE MORE THAN 4' (1.2m) HIGHER THAN THE HEAT EXCHANGER, OR BOTH, THE PIPE SIZE SHALL BE INCREASED BY AT LEAST ONE SIZE.
 - ALL PIPING CONNECTIONS FOR COOLING WATER FROM THE PUMP TO THE CUSTOMER CONNECTIONS ON THE ENCLOSURE ARE TO BE INSTALLED BY THE CUSTOMER PER NFPA 20.
 - THIS PACKAGE WILL REQUIRE A HIGH-CUBE CONTAINER FOR SEA FREIGHT)
 - THE LOOP SHOWN IS BASED ON STANDARD LOOP CONSTRUCTION AND FM SIZING CONDITIONS. FOR ALTERNATE LOOP CONSTRUCTION (STAINLESS STEEL, SEA WATER, AND HIGH PRESSURE) SIZES MAY VARY.

BOUNDARY BOX SHOWS MINIMUM CLEARANCE AROUND ENCLOSURE

REV	DESCRIPTION	ECN#	DWN	APVD	DATE
A	PRELIMINARY ENGINE DRAWING	5076	CRD	ACH	16OCT18

ENGINE MODELS	DIMENSIONS	CARBON STEEL	316 STAINLESS STEEL	CARBON STEEL SPARK ARRESTING	STAINLESS STEEL SPARK ARRESTING	COOLING WATER		FUEL LINE SIZE	
						SUPPLY	RETURN	SUPPLY	RETURN
JW6H-UFAA60, UFAA80, UFAD70, UFAD80,UFADFO, UFAJ80	A	85.6	89.1	97.6	100.6	1.25"	1.5"	.5" MINIMUM	.375" MINIMUM
	B	106.88	106.88	107.88	107.88				
	C			7.2					
	D			6					
	E	121.9	122.9	123.9	124.9				

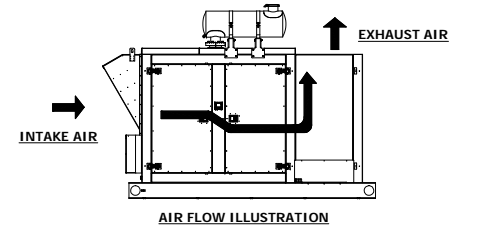
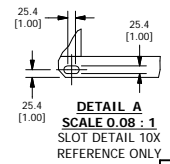
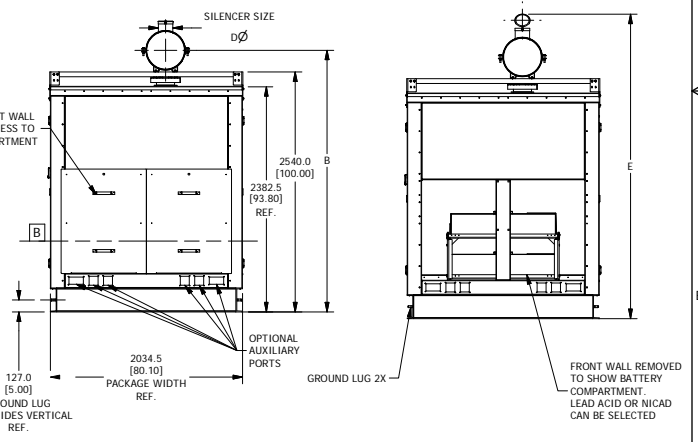

DRAWING SUBJECT TO CHANGE WITHOUT NOTICE DO NOT SCALE

<p>THIS DRAWING AND THE INFORMATION HEREON ARE OUR PROPERTY AND MAY BE USED BY OTHERS ONLY AS AUTHORIZED BY US IN WRITING. ALL RIGHTS ARE RESERVED UNDER THE COPYRIGHT LAWS.</p>		<p>CONTROLLED DRAWING</p>
<p>DESIGNED BY: CDYER</p>	<p>DATE: 12/21/2017</p>	<p>PROJECT: SUBMITTAL JW6H SOUND ATTENUATED MODULAR SIZE 2 ENCLOSURE WITH CRITICAL GRADE SILENCER</p>
<p>DRAWN BY: AHIGGINS</p>	<p>SCALE: N/A</p>	<p>PART NO: C137345</p>
<p>ASSEMBLY:</p>	<p>UNIT: NTS</p>	<p>PAGE: 1 OF 1</p>

DATUMS

- A- MOUNTING FACE OF FLYWHEEL
- B- ENGINE CRANKSHAFT CENTERLINE
- D- PUMP OR RIGHT ANGLE GEAR SHAFT HORIZONTAL CENTERLINE
- E- END OF PUMP OR RIGHT ANGLE GEAR SHAFT

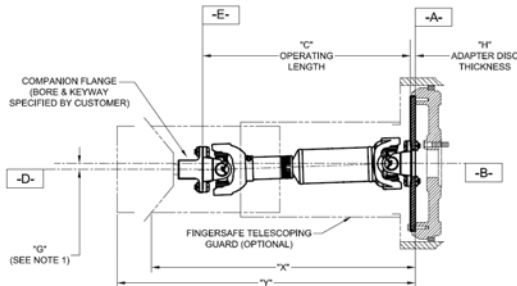

REV	DESCRIPTION	ECN#	DWN	APVD	DATE
A	PRELIMINARY ENGINEERING DRAWING	5076	ACH	ACH	05MAR18
B	REMOVED OBSOLETE MODELS AND ADDED NEW HIGH SPEED JU6H MODELS	5076	ACH	ACH	28SEP18
C	DRIVESHAFT MODEL NUMBER CHANGE	5076	CRD	JCA	29NOV18
D	ADDED CAT18 MODELS AND UPDATED OFFSET AND TOLERANCES FOR VA2365 DRIVESHAFTS	5076	ACH	ACH	10APR19
E	CORRECTED DRIVESHAFT SELECTIONS FOR DS0H-UFAA98, DT2H-UFAA20,50,58, AND DT2R-UFAA19,49	5076	ACH	ACH	03OCT19

Clarke Engines, UL/FM approved Heat Exchanger and Radiator Cooled Models	UL Listed Driveshaft Model	Non-Listed Driveshaft Model	Drive Disc	Companion Flange	Driveshaft Model Without Torsional Coupling (See Note 3)	"G" Vertical Parallel Offsets of Shafts	Torsional Coupling Model	Driveshaft Model With Torsional Coupling (See Note 3)	"G" Vertical Parallel Offsets of Shafts
JU4H-UFAEA0, UF10, 12, 04, 14, 20, 22, UF24	CDS10		C08448	CF10	CDS10-31	24.6 ±12.2 [0.97] ±[0.48]	TC15-11.5-41-FS	CDS10-29	22.8 ±11.4 [0.90] ±[0.45]
JU4R-UF09, 11, 13, 19, 21, 23, AEA9	CDS10		C08448	CF10	CDS10-31	24.6 ±12.2 [0.97] ±[0.48]	TC15-11.5-41-FS	CDS10-29	22.8 ±11.4 [0.90] ±[0.45]
JU4H-UF34, H0, AEE8, AEF2, ADJ8, ADJ2, H2, 40, 42 (Note 2)	CDS20		C08448	CF20	CDS20-31	24.0 ±12.0 [0.95] ±[0.47]	TC15-11.5-55-FS	CDS20-28	21.6 ±10.8 [0.85] ±[0.43]
JU4H-UF34, H0, AEE8, AEF2, ADJ8, ADJ2, H2, 40, 42 (Note 2)	CDS20		C08448	CF20	CDS20-31	24.0 ±12.0 [0.95] ±[0.47]	TC25-11.5-55-FS	CDS20-28	21.3 ±10.6 [0.84] ±[0.42]
JU4R-UF40, UFAEE7, AEF1	CDS20		C08448	CF20	CDS20-31	24.0 ±12.0 [0.95] ±[0.47]	TC15-11.5-55-FS	CDS20-28	21.3 ±10.6 [0.84] ±[0.42]
JU4H-UF58, AD58, UF50, UF52, UF54, ADJG, ADP0, ADRO, ADW8, ADY8	CDS30		C083762	CF30	CDS30-31	22.7 ±11.3 [0.89] ±[0.45]	TC25-11.5-61-FS	CDS30-28	20.0 ±10.0 [0.79] ±[0.39]
JU4R-UF49, 51, 53	CDS30		C083762	CF30	CDS30-31	22.7 ±11.3 [0.89] ±[0.45]	TC25-11.5-61-FS	CDS30-28	20.0 ±10.0 [0.79] ±[0.39]
JU4H-UFAD98	CDS50		C083763	CF50	CDS50-31	21.6 ±10.8 [0.85] ±[0.42]	TC35-11.5-81-FS	CDS50-28	18.9 ±9.4 [0.74] ±[0.37]
JU6H-UF00, D2, 30, 32, 34	CDS20		C08448	CF20	CDS20-31	24.0 ±12.0 [0.95] ±[0.47]	TC25-11.5-55-FS	CDS20-28	21.3 ±10.6 [0.84] ±[0.42]
JU6H-UFM8, M0, M2, 58, ADMG, 50, 52, 54, ADK0, ADNG, ADN0, ADQ0, ADRO, 60, 62, 84	CDS30		C083762	CF30	CDS30-31	22.7 ±11.3 [0.89] ±[0.45]	TC35-11.5-61-FS	CDS30-28	20.0 ±10.0 [0.79] ±[0.39]
JU6H-UF94		VA61A	C083762	CF30	VA61A-31	22.7 ±11.3 [0.89] ±[0.45]	TC35-11.5-61-FS	VA61A-28	20.0 ±10.0 [0.79] ±[0.39]
JU6H-UFAAPG, Q8, AARG, ADP8, AD88, ADR8, ADS8, AAS0, ADW8, AD98, ADX8	CDS50		C083763	CF50	CDS50-31	21.6 ±10.8 [0.85] ±[0.42]	TC35-11.5-81-FS	CDS50-28	18.9 ±9.4 [0.74] ±[0.37]
JU6H-UFADW8, AD98, ADX8, AAT8	CDS50		C083763	CF50	CDS50-31	21.6 ±10.8 [0.85] ±[0.42]	TC45-11.5-81-FS	CDS50-28	18.9 ±9.4 [0.74] ±[0.37]
JU6H-UFADP0, ADT0, AAT0, AAT2	CDS50	VA81A ³	C083763	CF50	CDS50-31 VA81A-31	21.6 ±10.8 [0.85] ±[0.42]	TC35-11.5-81-FS	CDS50-28 VA81A-28	18.9 ±9.4 [0.74] ±[0.37]
JU6R-UFAAD9, D1, 29, 31, 33	CDS20		C08448	CF20	CDS20-31	24.0 ±12.0 [0.95] ±[0.47]	TC25-11.5-55-FS	CDS20-28	21.3 ±10.6 [0.84] ±[0.42]
JU6R-UFAAM7, M9, M1, 57, 49, 51, 53, 59, 61, 83	CDS30		C083762	CF30	CDS30-31	22.7 ±11.3 [0.89] ±[0.45]	TC35-11.5-61-FS	CDS30-28	20.0 ±10.0 [0.79] ±[0.39]
JU6R-UFAAPF, Q7, RF, S9	CDS50		C083763	CF50	CDS50-31	21.6 ±10.8 [0.85] ±[0.42]	TC35-11.5-81-FS	CDS50-28	18.9 ±9.4 [0.74] ±[0.37]
JW 6H-UFAD00, ADF0	CDS50		C083763	CF50	CDS50-31	21.6 ±10.8 [0.85] ±[0.42]	TC45-11.5-81-FS	CDS50-28	18.9 ±9.4 [0.74] ±[0.37]
JW 6H-UFADJ0	CDS50		C083763	CF50	CDS50-31	21.6 ±10.8 [0.85] ±[0.42]	TC50-11.5-81-FS	CDS50-25	16.2 ±8.1 [0.64] ±[0.32]
JW 6H-UFAD70	CDS50		C083763	CF50	CDS50-31	21.6 ±10.8 [0.85] ±[0.42]	TC50-11.5-81-FS	CDS50-25	16.2 ±8.1 [0.64] ±[0.32]
JW 6H-UFAD80, AA80	CDS50 ^{1,2}	VA81A ^{1,3}	C083763	CF50	CDS50-31 VA81A-31	21.6 ±10.8 [0.85] ±[0.42]	TC50-11.5-81-FS	CDS50-25 VA81A-25	16.2 ±8.1 [0.64] ±[0.32]
JW 6H-UFAA60 3		VA81A ³	C083763	CF50	VA81A-31	21.7 ±10.9 [0.85] ±[0.42]	TC50-11.5-81-FS	VA81A-25	16.2 ±8.1 [0.64] ±[0.32]

NOTES:

- CAUTION: THE DRIVESHAFT IS DESIGNED TO OPERATE AT A 2° ANGLE WITH THE INPUT AND THE OUTPUT SHAFTS IN PARALLEL OFFSET OF "G" INCH VERTICALLY ABOVE OR BELOW THE ENGINE CRANKSHAFT CENTERLINE (DATUM B). THE OFFSET SHOULD BE 0.00" PARALLEL OFFSET HORIZONTALLY RIGHT OR LEFT OF DATUM B. REFER TO THE CERTIFIED DRIVESHAFT INSTALLATION MANUAL FOR ALIGNMENT INSTRUCTIONS.
- BASED ON THE TORSIONAL VIBRATION ANALYSIS (TVA) THE SIZE OF THE TORSIONAL COUPLING COULD CHANGE TO A SMALLER **TC15-11.5-55-FS**. **NOTE: THIS WILL AFFECT THE FINAL INSTALLATION (DIMENSIONS "C" SHOWN IN THE DIAGRAM AT THE TOP OF THE PAGE). THE PUMP INSTALLER MUST BE MADE AWARE OF THIS CHANGE.**
- LENGTHS SHOWN USE THE VALUE FOR THE LISTED DRIVESHAFT WHERE AVAILABLE.

- 1760 RPM ONLY
- 2100 RPM ONLY
- 2350 RPM ONLY
- 1470 RPM ONLY
- 1800 RPM ONLY
- 2650 RPM ONLY
- 1900 RPM ONLY

THIS DRAWING AND THE INFORMATION HEREON ARE OUR PROPERTY AND MAY BE USED BY OTHERS ONLY AS AUTHORIZED IN WRITING UNDER THE CONTROLLED DRAWING SYSTEM.			
DRAWING TITLE: ENCLOSED UNIT TORSIONAL COUPLING AND/OR DRIVESHAFT SELECTION MATRIX	DATE: 2/22/2018	DRAWING NO.: D769	SHEET NO.: 1 OF 2
DESIGNER: AHIGGINS CHECKER: AHIGGINS APPROVER: AHIGGINS	MATERIAL:	ASSEMBLY: ENCLOSEURE REDESIGN	SCALE: N/A
TOLERANCES UNLESS OTHERWISE SPECIFIED:	DIMENSIONS:	FINISH:	UNIT: MM (INCH)

